

Grease separator EasyClean free Basic, NS 2, Standard, universal

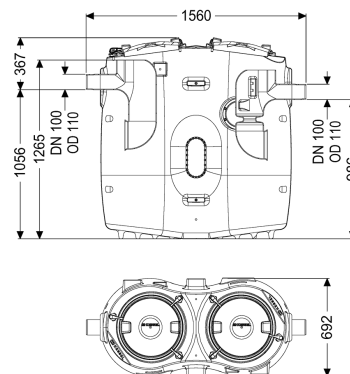

Article information

Item no.: 94002.10
 GTIN: 4026092084731
 Price group: 60

Advantages

- Low-maintenance operation

Description

The separator for greasy wastewater is suitable for free-standing set-up in frost-protected rooms and comes without metallic components in the tank. The collecting tank made of permanently resistant polymer (PE) is equipped with an integrated sludge trap. Two odour-tight covers with quick-release closures allow for easy access for cleaning and maintenance work. Manual disposal is carried out with the tank open. 20 year polyethylene warranty.

Variant

Direction of flow:	universal
Disposal variant:	Standard
Sludge bucket:	no
Nominal size (NS):	2
Refill inlet in accordance with DIN 1988:	no
Type of disposal:	manual with suction hose
Sampling device:	no
Load-bearing capacity (DIN 19901):	F3

General characteristics

Material:	PE
Standard:	EN 1825
Installation situation:	free-standing installation
Delivery state:	Installation-ready (connection parts must be connected on site)

Dimensions

Net weight:	70 kg
Gross weight:	95 kg
Set-up area, length:	1560 mm
Set-up area, width:	700 mm
Set-up area, height:	1420 mm
Required access area, length:	1560 mm
Required access area, width:	700 mm
Required access area, height:	1420 mm
Packaging dimension:	length
Packaging dimension:	width
Packaging dimension:	height

Tank/drain body

Nominal pressure (PN):	10
Pressure pipe connection (DN):	65
Pressure pipe connection (OD):	75 mm
Distance from centre of outlet pipe to tank bottom:	985 mm
Distance pipe bottom outlet to tank bottom:	985 mm
Distance pipe bottom inlet to tank bottom:	1055 mm
Outlet nominal size (OD):	110 mm
Outlet nominal size (DN):	100 mm
Inlet depth chamber:	1055 mm
Inlet nominal size (OD):	110 mm
Inlet nominal size (DN):	100 mm
Connection inlet/outlet sockets:	PE-HD pipes in accordance with DIN 19537, HT pipes in accordance with DIN 19560, PP or AS

Coverage features

Type of cover:	Cover
Cover material:	Polymer
Colour of cover:	violet
Locking:	Quick-release closure
Tightness:	odour-tight

Wastewater contents

Separator contents:	460 l
Max. grease layer thickness:	120 mm
Total volume:	660 l
Contents of sludge trap:	200 l
Storage quantity of grease:	80 l