

## Grease separator EasyClean free NS 15, Mix, left

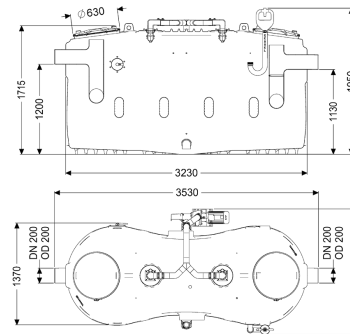

### Article information

Item no.: 93015-01-DS-L

GTIN: 4026092105153

Price group: 60

### Advantages

- Direction of flow can be changed thanks to self-sealing interchangeable hubs (NS 2- NS 10)
- Simple control
- Low-maintenance operation

### Description

The separator for greasy wastewater is suitable for free-standing set-up in frost-protected rooms and comes without metallic components in the tank. The collecting tank made of permanently resistant polymer (PE) is equipped with an integrated sludge trap and has a tapered base for fast and clean disposal. Two odour-tight covers with quick-release closures make easy access possible for cleaning and maintenance work. The innovative Shredder-Mix-System with integrated macerating system is responsible for homogenising and circulating the tank contents. Cleaning is carried out by an exterior pump which can be disconnected from the tank by a shut-off valve. After disposal, a maximum of 3 litres residual sludge volume is left in the tank. A direct disposal pipe socket is available for odour-neutral manual disposal. 20 year polyethylene warranty.

#### Variant

Shut-off valve:	yes
Direction of flow:	left
Disposal variant:	Mix
Shredder-Mix-System:	yes
Sludge bucket:	no
Nominal size (NS):	15
SonicControl:	no
Disposal system:	Disposal connection
Refill inlet in accordance with DIN 1988:	yes
Type of disposal:	manual cleaning system
Water supply:	1 screw-type valve 1"

Load-bearing capacity (DIN 19901):	F3
<b>General characteristics</b>	
Material:	PE
Installation situation:	free-standing installation
Delivery state:	Installation-ready (electrical components, connection parts must be connected on site)
Scope of delivery:	Storz-B coupling R 2 1/2" for disposal vehicle connection
<b>Dimensions</b>	
Net weight:	410 kg
Gross weight:	485 kg
Set-up area, length:	3530 mm
Set-up area, width:	1680 mm
Set-up area, height:	1950 mm
Packaging dimension:	length
Packaging dimension:	width
Packaging dimension:	height
<b>Tank/drain body</b>	
Nominal pressure (PN):	10
Pressure pipe connection (DN):	65
Pressure pipe connection (OD):	75 mm
Distance pipe bottom outlet to tank bottom:	1130 mm
Distance pipe bottom inlet to tank bottom:	1200 mm
Outlet nominal size (OD):	200 mm
Outlet nominal size (DN):	200 mm
Inlet nominal size (OD):	200 mm
Inlet nominal size (DN):	200 mm
Connection inlet/outlet sockets:	PE-HD pipes in accordance with DIN 19537, HT pipes in accordance with DIN 19560, PP or AS
Servicing opening:	420 mm
<b>Coverage features</b>	
Type of cover:	Cover
Cover material:	Polymer
Colour of cover:	violet
Locking:	Quick-release closure
Tightness:	odour-tight
<b>Wastewater contents</b>	
Separator contents:	2230 l
Total volume:	3730 l
Contents of sludge trap:	1500 l
Storage quantity of grease:	600 l
<b>Pumping device</b>	
Number of pumps:	1
Connection type:	Direct connection

Rated current:	6,2 A
Length of mains cable for pump:	5 m
Protection class:	I
Cos phi - power factor:	0,87
Protection class (pump):	IP 55
Temperature monitoring:	integrated
Max. temperature (permanent) of conveyed material:	40 °C
Max. pumping capacity:	60 m <sup>3</sup> /h
Max. pumping height:	17 m
Speed:	2850 U/min
Power P1:	3,6 kW
Power P2:	3 kW
Operating mode:	S2 - 30 min.
Type of pump connection cable:	H07RN-F 7G 1.5 mm <sup>2</sup>
Impeller type:	Radial impeller with macerating system
Control	
Control unit:	yes
Type of fuse required (RCD):	30 mA
Mains frequency:	50 Hz
Operating voltage:	400 V
Connection type:	Direct connection
Rated current:	6,2 A