

## Ecolift XL backwater lifting st. Duo, 1 motor-driven flap, SPF 3000-S3

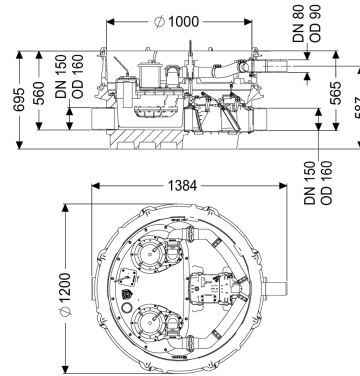

### Article information

Item no.: 8741024  
 GTIN: 4026092068410  
 Price group: 60

### Advantages

- Wastewater drainage without interruption, even if a power failure occurs, as long as there is no backwater
- low pump use
- minimised noise emissions

### Description

The backwater lifting station for faecal and non-faecal wastewater is equipped with two submersible pumps, one motor-driven and one mechanical closure system and a backflow preventer. The collection tank made of permanently resistant polymer (PE) has an enclosed pump tank. Quick-release closures enable the integrated components to be removed easily. Normally, draining takes place via the natural fall to the sewer. Backwater is detected by an optical probe, which causes the motor-driven closure system to close automatically and there is no longer free passage to the sewer. During the backwater phase, the water drains via a pressure pipe, which carries the wastewater into the sewer. The pressure pipe is a welded PE pipe; with pump SPF 4500, the pressure pipe must also be continued up to a pressure release chamber. The station is controlled by a user-friendly control unit, which is optionally integrated in the building management system via a potential-free contact, or alarm and collective fault messages can be output via a GSM interface. The KESSEL modular system provides different upper sections and engineering chamber options as accessories.

#### Variant

Note on installation depth:

Type of system:

Shut-off valve:

Passage seal for conduit pipe (DN):

Version for deeper installation

duo pump

Shut-off valve made of polymer

100

|  |  |
|--|--|
| Passage seal for ventilation pipe (DN):                | 70   |
| Pump control:  | Control unit   |
| Backflow preventer:                                    | integrated   |
| Pressure pipe connection:                              | horizontal   |
| Motor-driven backwater flaps:                          | 1  |
| Mechanical backwater flaps:                            | 1  |
| <br>   |  |
| General characteristics                                |  |
| Colour:  | black  |
| Standard:  | ÖNORM B 2501   |
| Type of wastewater:                                    | for wastewater with and without sewage   |
| Installation situation:                                | free-standing installation   |
| Delivery state:  | Pre-mounted for final assembly on site (pumps and sensor system must be fitted on site and control unit must be connected) |
| Backwater protection:                                  | Type 3   |
| Approval:  | Z-53.2-493   |
| <br>   |  |
| Dimensions   |  |
| Net weight:  | 152 kg   |
| Gross weight:  | 176 kg   |
| Groundwater resistant from lower edge of base section: | 3000 mm  |
| Vertical drop between inlet and outlet:                | 15 mm  |
| Length:  | 1384 mm  |
| Width:   | 1200 mm  |
| Height:  | 695 mm   |
| Packaging dimension:                                   | length   |
| Packaging dimension:                                   | width  |
| Packaging dimension:                                   | height   |
| <br>   |  |
| Tank/drain body  |  |
| Nominal pressure (PN):                                 | 10   |
| Pressure pipe connection (DN):                         | 80   |
| Pressure pipe connection (OD):                         | 90 mm  |
| Channel:   | continuous channel   |
| Venting connection (DN):                               | 70   |
| Distance pipe bottom outlet to tank bottom:            | 120 mm   |
| Distance pipe bottom inlet to tank bottom:             | 135 mm   |
| Number of outlets:                                     | 1  |
| Outlet nominal size (DN):                              | 150 mm   |
| Inlet nominal size (DN):                               | 150 mm   |
| Number of inlets:                                      | 1  |
| Clear width of tank (LW):                              | 1000 mm  |
| Pumping volume:  | 20 l   |
| Tank volume:   | 65 l   |
| <br>   |  |
| Pumping device   |  |
| Pump:  | SPF 3000-S3 EcoXL  |
| Number of pumps:                                       | 2  |

|  |                                |
|--|--------------------------------|
| Weight, pump:                                      | 24 kg                          |
| Connection type:                                   | Direct connection              |
| Rated current:                                     | 5,4 A                          |
| Protection class:                                  | I                              |
| Insulation class:                                  | F                              |
| Cos phi - power factor:                            | 0,89                           |
| Protection class (pump):                           | IP 68 (3m/48h)                 |
| Temperature monitoring:                            | integrated                     |
| Max. temperature (permanent) of conveyed material: | 40 °C                          |
| Max. pumping capacity:                             | 36 m <sup>3</sup> /h           |
| Max. pumping height:                               | 17,5 m                         |
| Speed:   | 2845 U/min                     |
| Power P1:  | 3,2 kW                         |
| Power P2:  | 2,7 kW                         |
| Operating mode:                                    | S3 - 50 %                      |
| Type of fuse required (electrical protection):     | 3 x C 20 A                     |
| Type of pump connection cable:                     | H07RN-F 7G 1.5 mm <sup>2</sup> |
| Impeller type:                                     | Multi-vane impeller            |
| Free passage:                                      | 40 mm                          |
| Length of mains cable for pump:                    | 10 m                           |
| <br>   |                                |
| Control  |                                |
| Control unit:                                      | Comfort Plus                   |
| Motor protection switch:                           | yes                            |
| Standby power:                                     | 5 W                            |
| Alarm sensor:                                      | optical probe                  |
| Level measurement instrument:                      | Immersion pipe                 |
| Type of level measurement:                         | pneumatic                      |
| Protection class control unit:                     | IP 54                          |
| Operating voltage:                                 | 400 V                          |
| Connection type:                                   | Direct connection              |
| Potential-free contact:                            | yes                            |
| GSM interface:                                     | yes                            |
| USB interface:                                     | yes                            |
| Log book function:                                 | yes                            |
| Multi-line display:                                | yes                            |
| Battery buffering:                                 | yes                            |
| Self-diagnosis system (SDS):                       | yes                            |
| Type of fuse required (electrical protection):     | 3 x C 20 A                     |