

Lifting station Aqualift F Duo Comfort, SPF 3000-S3

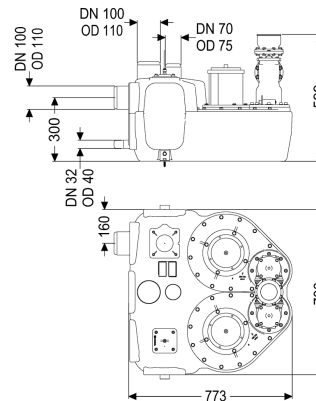

Article information

Item no.: 28765
 GTIN: 4026092054567
 Price group: 20

Advantages

- Different performance classes available
- Pressure sensor for reliable pneumatic level measurement
- Control unit with self-diagnosis system

Description

The lifting station for faecal and faecal-free wastewater is equipped with two submersible pumps and a backflow preventer. The collection tank made of permanently resistant polymer (PE) offers universal connection options and has a screwed access cover.

Variant

| | |
|--|--|
| Type of system: | duo pump |
| Shut-off valve: | without shut-off valve |
| Retaining bracket for the lift protection: | yes |
| Sound absorption mat: | yes |
| Pump control: | Control unit |
| Backflow preventer: | integrated |
| Pressure pipe connection: | vertical |
| | |
| General characteristics | |
| Colour: | black |
| Standard: | EN 12050-1 |
| Type of wastewater: | with sewage |
| Installation situation: | free-standing installation |
| Delivery state: | Installation-ready (electrical components, connection parts must be connected on site) |

Dimensions

Net weight: 78 kg

| | |
|--|--------------------------------|
| Gross weight: | 100 kg |
| Length: | 773 mm |
| Width: | 780 mm |
| Height: | 539 mm |
| Packaging dimension: | length |
| Packaging dimension: | width |
| Packaging dimension: | height |
| Tank/drain body | |
| Pressure pipe connection (DN): | 100 |
| Pressure pipe connection (OD): | 110 mm |
| Connection for manual diaphragm pump (DN): | 32 |
| Venting connection (DN): | 70 |
| Distance pipe bottom inlet to tank bottom: | 245 mm |
| Distance from centre of inlet pipe to tank bottom: | 300 mm |
| Inlet max. scoring (DN): | 150 mm |
| Inlet nominal size (OD): | 110 mm |
| Inlet nominal size (DN): | 100 mm |
| Number of inlets: | 2 |
| Pumping volume: | 50 l |
| Tank volume: | 120 l |
| Pumping device | |
| Pump: | SPF 3000-S3 |
| Number of pumps: | 2 |
| Weight, pump: | 24 kg |
| Connection type: | Direct connection |
| Rated current: | 5,4 A |
| Protection class: | I |
| Insulation class: | F |
| Cos phi - power factor: | 0,89 |
| Protection class (pump): | IP 68 (3m/48h) |
| Temperature monitoring: | integrated |
| Max. temperature (permanent) of conveyed material: | 40 °C |
| Max. pumping capacity: | 47 m ³ /h |
| Max. pumping height: | 16 m |
| Speed: | 2845 U/min |
| Power P1: | 3,2 kW |
| Power P2: | 2,7 kW |
| Operating mode: | S3 - 50 % |
| Type of pump connection cable: | H07RN-F 7G 1.5 mm ² |
| Impeller type: | Multi-vane impeller |
| Free passage: | 40 mm |
| Length of mains cable for pump: | 5 m |
| Control | |
| Control unit: | Comfort |
| Motor protection switch: | yes |

| | |
|--------------------------------|--------------------------------------|
| Alarm sensor: | Immersion pipe |
| Level measurement instrument: | Immersion pipe with pressure monitor |
| Type of level measurement: | pneumatic |
| Protection class control unit: | IP 54 |
| Mains frequency: | 50 Hz |
| Operating voltage: | 400 V |
| Connection type: | Direct connection |
| Potential-free contact: | yes |
| GSM interface: | yes |
| Log book function: | yes |
| Multi-line display: | yes |
| Battery buffering: | yes |
| Self-diagnosis system (SDS): | yes |