

Lifting station Aqualift S 100 Tronic, GTF 600, Free-standing set-up

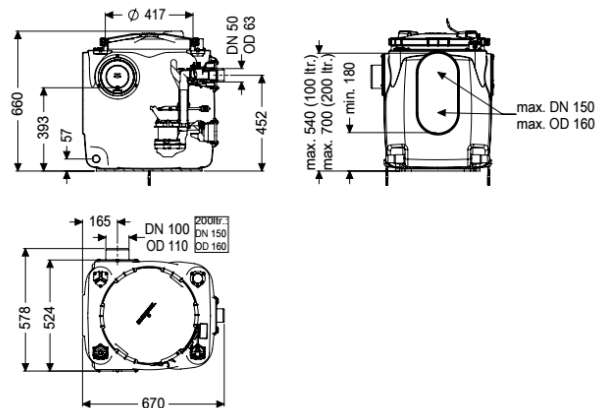

Article information

Item no.: 28513
 GTIN: 4026092092897
 Price group: 20

Advantages

- Easy tool-free maintenance
- Tank made of PE, resistant to aggressive wastewater
- Including backflow preventer for the pressure pipe

Description

The ready to plug in lifting station for faecal-free wastewater is equipped with one or two submersible pumps and a backflow preventer. The collection tank made of permanently resistant polymer (PE) has an open pump tank. One-handed closures enable easy removal of the integrated components.

Variant

Type of system:	Single unit
Pump control:	Control unit
Backflow preventer:	integrated

General characteristics

Colour:	black
Standard:	EN 12050-2
Type of wastewater:	without sewage
Installation situation:	free-standing installation
Delivery state:	Pre-mounted for final assembly on site (pumps and sensor system must be fitted on site and control unit must be connected)

System type:	Tronic
--------------	--------

Dimensions

Net weight:	29,9 kg
Gross weight:	29,9 kg

Length:	670 mm
Width:	530 mm
Height:	650 mm
Packaging dimension:	length
Packaging dimension:	width
Packaging dimension:	height
Tank/drain body	
Pressure pipe connection (DN):	50
Pressure pipe connection (OD):	63 mm
Inlet nominal size (DN):	100 mm
Pumping volume:	50 l
Tank volume:	120 l
Coverage features	
Type of cover:	Cover
Cover material:	Polymer
Colour of cover:	violet
Locking:	Quick-release closure
Tightness:	odour-tight
Pumping device	
Pump:	GTF 600
Number of pumps:	1
Weight, pump:	6 kg
Connection type:	coded plug
Rated current:	2,9 A
Length of mains cable for pump:	5 m
Protection class:	I
Insulation class:	F
Protection class (pump):	IP 68 (3m)
Temperature monitoring:	integrated
Max. temperature (permanent) of conveyed material:	40 °C
Max. pumping capacity:	12 m ³ /h
Max. pumping height:	8 m
Speed:	2750 U/min
Power P1:	0,65 kW
Power P2:	0,4 kW
Operating mode:	S1
Type of fuse required (electrical protection):	C 16 A
Type of pump connection cable:	H07RN-F 3G 1.5 mm ²
Impeller type:	Multi-vane impeller
Free passage:	10 mm
Control	
Control unit:	Comfort
Control unit function:	With alarm message
Motor protection switch:	yes
Level measurement instrument:	Immersion pipe

Type of level measurement:	pneumatic
Protection class control unit:	IP 54
Mains frequency:	50 Hz
Operating voltage:	230 V
Connection type:	coded plug
Length of mains cable for control unit:	1,4 m
Potential-free contact:	optional
GSM interface:	yes
USB interface:	yes
Log book function:	yes
Multi-line display:	yes
Battery buffering:	yes
Self-diagnosis system (SDS):	yes
Warning equipment version:	acoustic and optical signal
Rated current:	2,9 A