

Drehfix basement drain DN 100, Black grating, Type 5

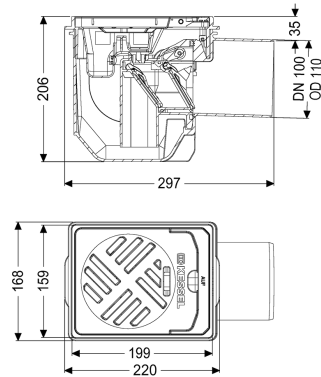

Article information

Item no.: 27301
 GTIN: 4026092007815
 Price group: 10

Advantages

- Integrated backwater protection
- Simple toolless maintenance and cleaning

Description

The basement drain for faecal-free wastewater is equipped with two mechanical flaps which close automatically in the event of backwater. One flap serves at the same time as an emergency closure to be closed by hand.

Variant

Contents of sludge trap:	yes
Emergency closure:	yes
Discharge rate (l/s) with 20 mm threshold:	1,8
Mechanical backwater flaps:	2

General characteristics

Colour:	black
Standard:	EN 1253
Nominal size (DN):	100
Outer diameter (OD):	110 mm
Type of wastewater:	without sewage
Installation situation:	floor slab installation
Delivery state:	installation-ready
Backwater protection:	Type 5
Odour trap:	included

Dimensions

Net weight:	1,49 kg
Gross weight:	1,51 kg
Cutout dimension, width:	190 mm

Cutout dimension, length:	320 mm
Installation depth:	210 - 240 mm
Type of height adjustability:	vertically adjustable upper section
Length:	285 mm
Width:	168 mm
Packaging dimension:	length
Packaging dimension:	width
Packaging dimension:	height

Coverage features

Type of cover:	Slotted cover
Colour of cover:	black
Load class:	K 3 (EN 1253-1)
Grating material:	Polymer
Grating colour:	black
Grid size, length:	190 mm
Grid size, width:	150 mm
Grid size, height:	14 mm
Contents of sludge trap:	yes

Cover

Grating colour:	black
Grating material:	Polymer
Grid size, length:	190 mm
Grid size, width:	150 mm
Grid size, height:	14 mm